

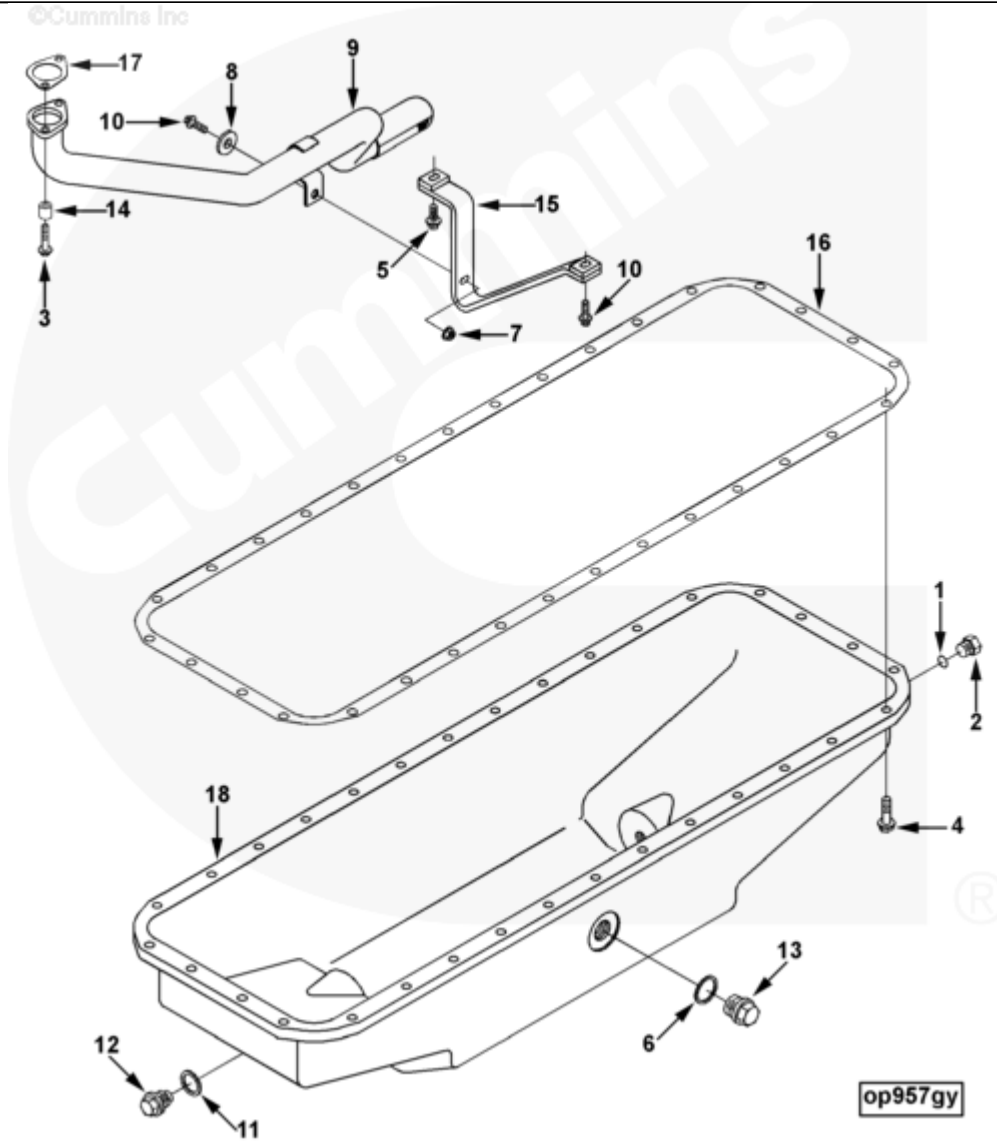

Parts Catalog - Option Detail

Electronic Parts Catalog - Option Detail				
Option	Group	Graphic	Film Card	Date
OP9351-02	07.01	op957gy	Z	03-MAR-04
Engines	6C8.3, C GAS PLUS CM556, G8.3, G8.3 CM558, GTA8.3 CM558, ISC CM2150, ISC CM554, ISC CM850, ISC8.3 CM2250, ISC8.3 G CM2180 C101, ISL CM2150, ISL CM554, ISL CM850, ISL G CM2180, ISL8.9 CM2150 L110, ISL8.9 CM2880 L112, ISL9 CM2150 SN, ISL9 CM2250, ISL9 CM2350 L101, ISL9 CM2350 L111, ISLE4 CM850, L GAS PLUS CM556, L8.9, L8.9 L121, L8.9G CMOH2.0 L125B, L9 CM2350 L116B, L9 CM2350 L119B, L9 CM2350 L120C, L9 CM2350 L123B, L9.3 L105, L9.5 L117, L9N CM2380 L124B, QSC8.3 CM2250, QSC8.3 CM2880 C102, QSC8.3 CM554, QSC8.3 CM850(CM2850), QSL9 CM2250, QSL9 CM2250 L115, QSL9 CM2350 L102, QSL9 CM2350 L107, QSL9 CM2350 L118, QSL9 CM2350 L122, QSL9 CM554, QSL9 CM850(CM2850), QSL9 G CM558, QSL9 M CM2250 L106, QSL9.3 CM2880 L113			



SMALL | MEDIUM | LARGE

Cart	Ref No	Part Number	Part Description	Required	Remarks
------	--------	-------------	------------------	----------	---------

View My Cart

		OP9351-02	Oil Pan		MR - PAN, OIL...(More)
					Engine Family: C Series
					Cylinders: 6
					Sump Style: Standard
					Sump Location: Center
					Oil Pan Material: Cast
					Aluminum
					Oil Pan Type: Non-Isolated
					Pan High Capacity (qt): 20
					(18.93 L)
					Pan Low Capacity (qt): 16
					(15.14 L)
					Pan Front Up Angularity
					(deg): 45
					Pan Front Down Angularity
					(deg): 35
					Pan Side to Side Angularity
					(deg): 45
					Drain Size: M18
					Drain Location: Facing Front
					Face of Block
					Position from Front Face of
					Block (mm): 222
					Position from Crank
					Centerline (mm): 290
					Heater Boss Size: M22 x
					1.5-6H
					Heater Boss Location: Fuel

					Pump Side
					Position from Front Face of
					Block (mm): 443
					Position from Crank
					Centerline (mm): 213.8
					Required Block Flange (mm):
					282 x 883.5
					Oil Pan Mounting Holes: 9mm
					Thru Holes
					Oil Pan/Block Mounting
					Holes: 24
					Spacing: Equal, 78.5mm
					Oil Pan/Gear Housing
					Mounting Holes: 4
					Spacing: Unequal
					Oil Pan/Flywheel Housing
					Mounting Holes: 4
					Spacing: Unequal
					Doweled for Flywheel Housing:
					No
					Required Dipstick
					Calibration: TBD
					BFOB-Full/Low 0-5 Degrees:
					64/82
<input type="checkbox"/>		3040995	Threaded Plug	1	9/16 - 18 UNF
<input type="checkbox"/>	1	3037537	O-Ring Seal	1	
	2	3040809	Threaded Plug	1	
<input type="checkbox"/>	3	3900628	Hexagon Flange Head Cap Screw	2	M6 X 1.00 X 30.
<input type="checkbox"/>	4	3900631	Hexagon Flange Head Cap Screw	32	M8 X 1.25 X 25.

<input type="checkbox"/>	5	3901865	Hexagon Flange Head Cap Screw	1	M6 X 1.00 X 20.
<input type="checkbox"/>	6	3902425	Sealing Washer	1	M22
<input type="checkbox"/>	7	3906216	Hexagon Flange Nut	1	M6 X 1.00.
<input type="checkbox"/>	8	3910960	Plain Washer	1	M6
<input type="checkbox"/>	9	3912228	Oil Suction Connection	1	
<input type="checkbox"/>	10	3913638	Hexagon Flange Head Cap Screw	2	M6 X 1.00 X 16.
<input type="checkbox"/>	11	3920773	Sealing Washer	1	M18
<input type="checkbox"/>	12	3924147	Threaded Plug	1	M18 x 1.50 x 12
<input type="checkbox"/>	13	3924148	Threaded Plug	1	M22 x 1.50 x 14
<input type="checkbox"/>	14	3926865	Mounting Spacer	2	
<input type="checkbox"/>	15	3927611	Tube Brace	1	
<input type="checkbox"/>	16	3938160	Oil Pan Gasket	1	Refer To TSB050014.
<input type="checkbox"/>	17	3939352	Oil Suction Connection Gasket	1	
<input type="checkbox"/>	18	4003819	Oil Pan	1	